

# Instructions for a SMB1-DB Lighting Pole

**IMPORTANT NOTE:** Each SMB1 Pole Section & Base Ring is custom fitted together during finishing. Care must be taken by the installer to ensure each Pole Section is matched with the Base Ring it shipped with. Line up the two Alignment Marks (†) on the Base Ring and the Pole Section to ensure proper bolt installation. To confirm this, the Electrical Access Door will align with the Triangle markings (‡) engraved on the Base Ring. A liquid thread-lock is recommended for use on all hardware.

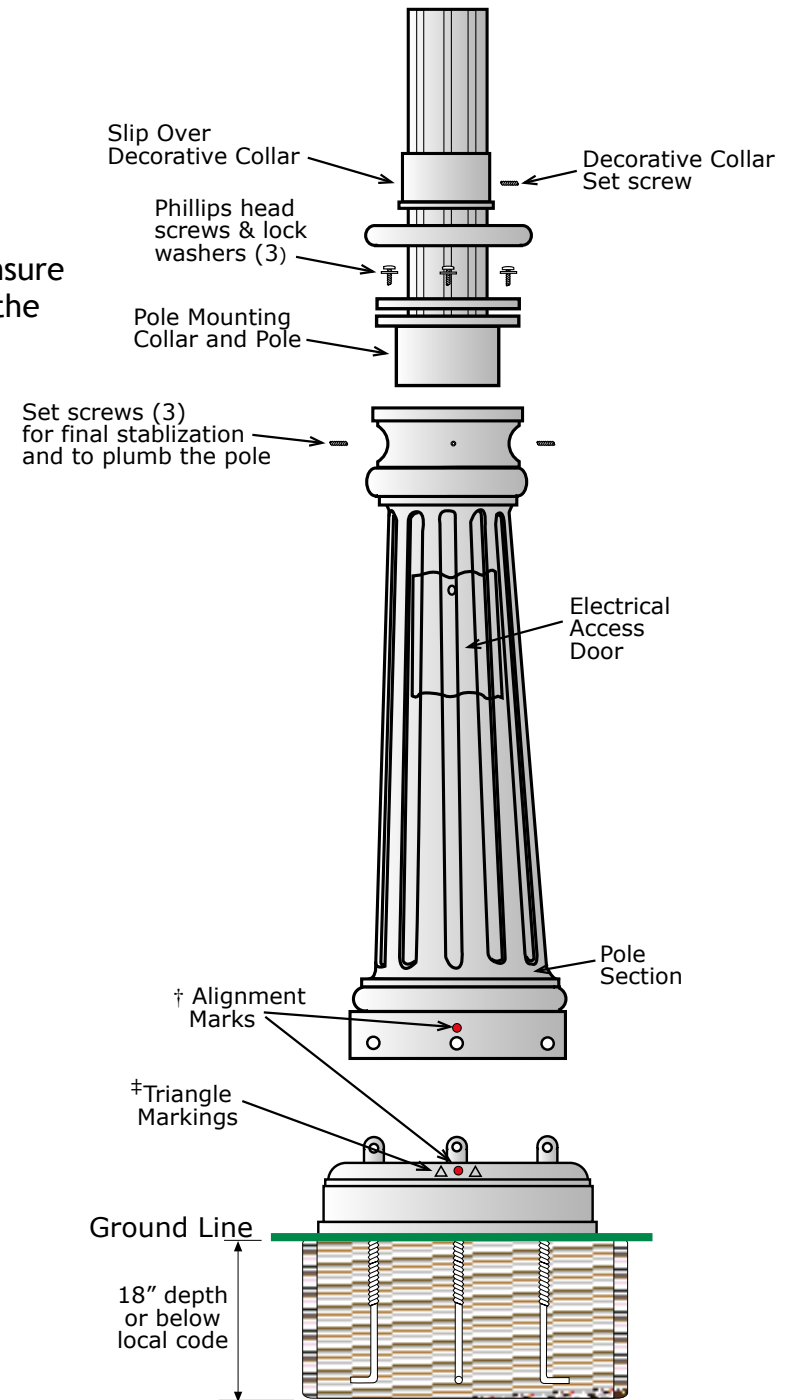
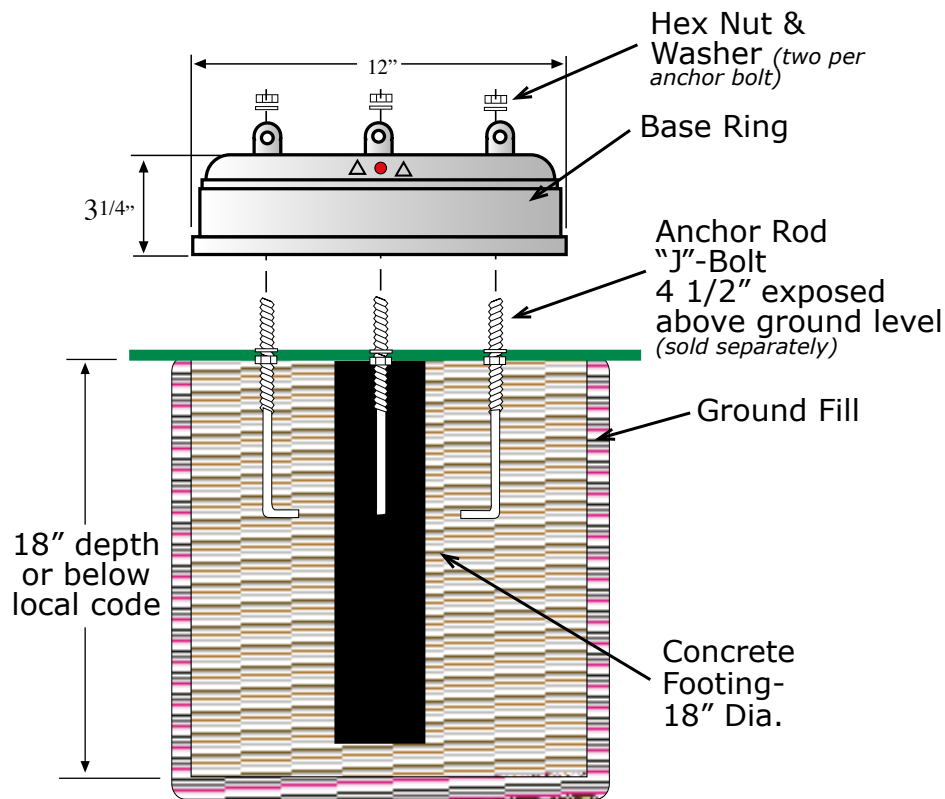

**\*SMBJ12 Mounting kit sold separately.**  
 SMBJ12 Mounting kit includes:  
 3-12" L-Bolts 1/2"  
 6- 1/2-13 Hex Nuts  
 3-1" Flat Washer  
 3 Lock Washers

# SMB1 Anchor Bolt Template

Cut out diagram on dotted lines

## Drawing To Scale

Due to different printer margins make sure to verify dimensions before using template.

